

# UMM-B2 & UMM-B3: Motor Dimensions

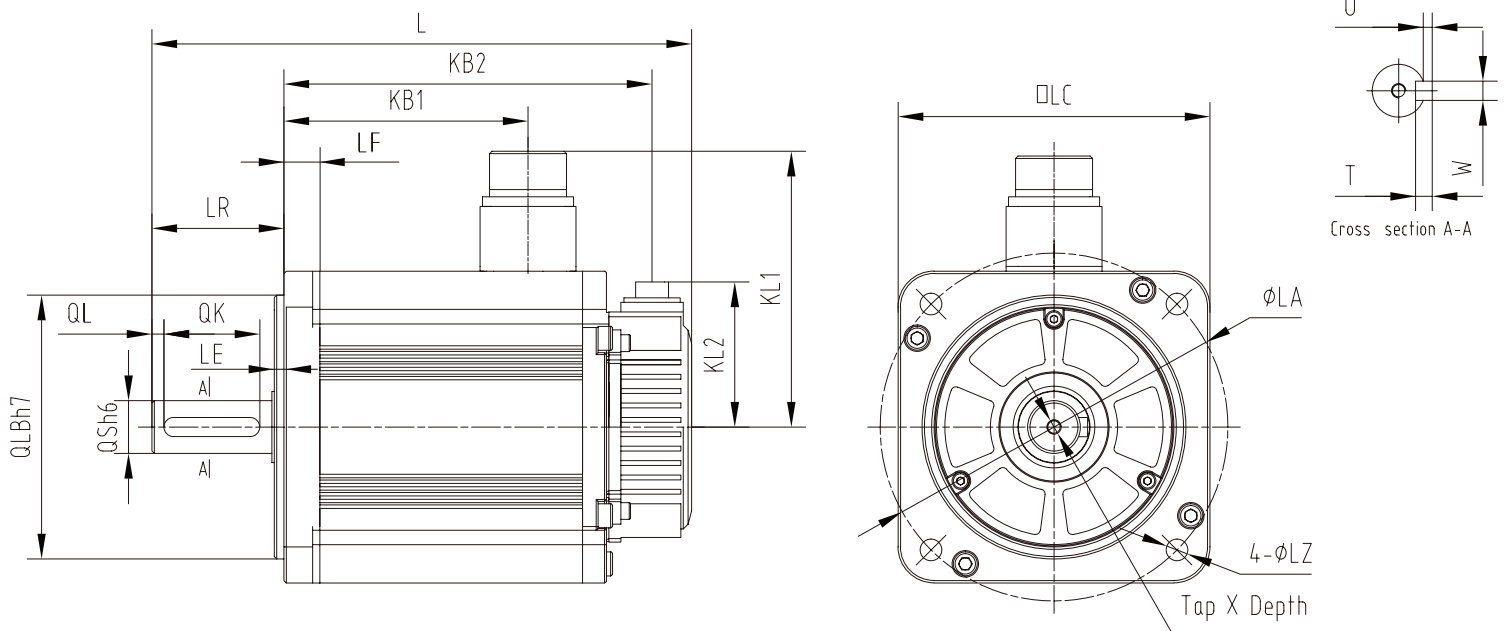

unit: mm

Part Number	L*	*LL	Flange Side							S	Tap x Depth	Key					KB1*	KB2*	KL1	KL2
			LR	LE	LF	LC	LA	LB	LZ			QK	W	T	U	Q				
UMM-0010EA□-B2	203 (245.5)	148 (190.5)	55	4	12	130	145	110	9	22	M6x20	40	5	8	7	4	80 (103.2)	131.5 (174)	117	60.5
UMM-0015CA□-B2	225 (267.5)	170 (212.5)															102 (125.2)	153.5 (196)		
UMM-0015EA□-B2	247 (289.5)	192 (234.5)															124 (147.2)	175.5 (218)		
UMM-0020CA□-B2																				
UMM-0020EA□-B2	247 (289.5)	192 (234.5)																		
UMM-0030CA□-B3	307 (378)	228 (299)	79	3.2	18	180	200	114.3	14	35	M8x16	55	6	10	8	5	143	203 (274)	140	79
UMM-0030EA□-B3	307 (378)	228 (299)															183	253 (324)		
UMM-0050CA□-B3	357 (428)	278 (349)																		
UMM-0050EA□-B3	357 (428)	278 (349)																		

\* The values in parentheses are for servo motors with holding brakes

□ - Add the letter B in the square in order to include holding brake eg. UMM-0010EA□-B2 -> UMM-0010EAB-B2



**UNITRONICS®**  
www.unitronics-cannabis.com